

LOOKING ON REAR OF RELAY

2112W50195

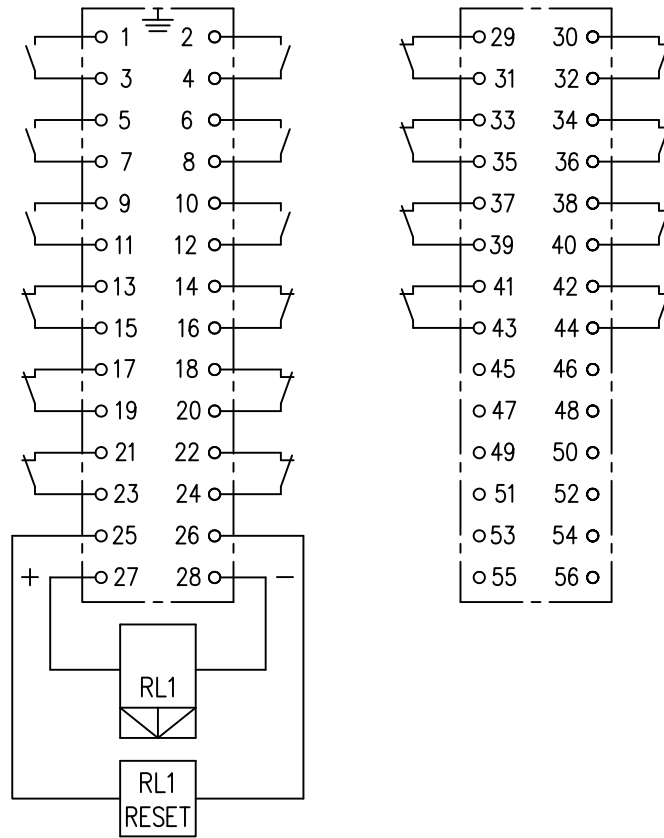

- KEY**
- make contact
  - break contact
  - c/o contact
  - ext. conn
  - plug bridge - shorting
  - metering point
  - 5Kv barrier
  - test socket - shorting
  - plug & socket

NOT SUBJECT TO UPDATE  
ONCE COPIED / PRINTED  
OR DOWNLOADED

FRAME TERMINAL BLOCK ASSY:-

ASSEMBLY INSTRUCTIONS:-  
TYPICAL ASSEMBLY DRAWING 2995G10032.  
AT INDICATED POSITIONS FIT AS FOLLOWS:  
T - FIT TRIP ISOLATION CONTACT 2995B10053  
S - FIT STANDARD CONTACT 2995B10054  
SECURE CONTACTS USING FIXING SCREW 2109F99009.  
POSITIONS SHOWN BLANK ARE UNUSED

30	T	T	29	2	T	T	1
32	T	T	31	4	T	T	3
34	T	T	33	6	T	T	5
36	T	T	35	8	T	T	7
38	T	T	37	10	T	T	9
40	T	T	39	12	T	T	11
42	T	T	41	14	T	T	13
44	T	T	43	16	T	T	15
46			45	18	T	T	17
48			47	20	T	T	19
50			49	22	T	T	21
52			51	24	T	T	23
54			53	26	S	S	25
56			55	28	S	S	27

VIEW FROM NUMBERED SIDE OF BLOCK

OUTER TERMINAL BLOCK ASSY:-

ASSEMBLY INSTRUCTIONS:-  
TYPICAL ASSEMBLY DRAWING 2995G10029.  
AT INDICATED POSITIONS FIT AS FOLLOWS:  
S - FIT STANDARD CONTACT 2995B10051  
HC - FIT 'HEAVY CURRENT' KIT 2995G10030  
WHERE IS SHOWN FIT CT SHORTING KIT 2995G10031  
POSITIONS SHOWN BLANK ARE UNUSED.  
ALL POSITIONS FIT SCREW 2106F12506.

30	S	S	29	2	S	S	1
32	S	S	31	4	S	S	3
34	S	S	33	6	S	S	5
36	S	S	35	8	S	S	7
38	S	S	37	10	S	S	9
40	S	S	39	12	S	S	11
42	S	S	41	14	S	S	13
44	S	S	43	16	S	S	15
46			45	18	S	S	17
48			47	20	S	S	19
50			49	22	S	S	21
52			51	24	S	S	23
54			53	26	S	S	25
56			55	28	S	S	27

VIEW FROM INSIDE FACE

1	24/11/09	MOD.No.	Title: TERM. BLOCK & WIRING DIAG. FOR 06M14B E/RESET TRIP RELAY IN E4 CASE			First used on:		
			SIEMENS PROTECTION DEVICES LTD.			Similar Articles:		
Original Scale:						Supersedes:		
			.			Drg.No. 2112W50195		
DRAWN: A.LAW.	CHECKED: RD.WATSON	APPROVED: RD.WATSON				DATE: 25/11/09	IE:	OPS: